



INSTYTUT TECHNIKI BUDOWLANEJ
PL 00-611 WARSZAWA
ul. Filtrowa 1
tel.: (+48 22) 825-04-71
(+48 22) 825-76-55
fax: (+48 22) 825-52-86
www.itb.pl



European Technical Assessment

**ETA-16/0444
of 30/06/2016**

General part

Technical Assessment Body issuing the European Technical Assessment

Instytut Techniki Budowlanej

Trade name of the construction product

WSW, WSWx, WSWOC, A2-WSW
WB6P, WB6P-D, A2-WB6P

Product family to which the construction product belongs

Fastening screws for sandwich panels

Manufacturer

KLIMAS Sp. z o.o.
ul. Wincentego Witosa 135/137
42-233 Mykanów
Poland

Manufacturing plant

WKREŃ-MET sp. z o.o., sp. komandytowa
ul. Wincentego Witosa 170/176
42-233 Mykanów
Poland

This European Technical Assessment contains

27 pages including 22 Annexes which form an integral part of this assessment

This European Technical Assessment is issued in accordance with regulation (EU) No 305/2011, on the basis of

European Assessment Document (EAD)
EAD 330047-01-0602 "Fastening screws for sandwich panels"

This European Technical Assessment is issued by the Technical Assessment Body in its official language. Translations of this European Technical Assessment in other languages shall fully correspond to the original issued document and shall be identified as such.

Communication of this European Technical Assessment, including transmission by electronic means, shall be in full. However, partial reproduction may only be made with the written consent of the issuing Technical Assessment Body. Any partial reproduction has to be identified as such.

Specific part

1. Technical description of the product

The fastening screws for sandwich panels WSW, WSWx, WSWOC, A2-WSW, WB6P, WB6P-D and A2-WB6P are a self-drilling and self-tapping screws listed in Table 1. Screws are completed with a steel or aluminum washer and an EPDM sealing ring. For details see the Annexes 2 to 21.

The fastening screw for sandwich panels and the corresponding connections are subject to tension and shear forces.

Table 1

No.	Screw	Material	Annex
1	WSWOC-6-5,5 × L	galvanized carbon steel with ≥ 12 µm of zinc	2, 3, 4, 5
2	WSWx-6-5,5 × L	galvanized carbon steel with ≥ 20 µm of zinc	2, 3, 4, 5
3	WSW-6-5,5 × L	galvanized carbon steel with ceramic coating	2, 3, 4, 5
4	A2-WSW-6-5,5 × L	stainless steel (bi-metal)	10, 11, 12, 13
5	WSWOC-12-5,5 × L	galvanized carbon steel with ≥ 12 µm of zinc	6, 7, 8, 9
6	WSWx-12-5,5 × L	galvanized carbon steel with ≥ 20 µm of zinc	6, 7, 8, 9
7	WSW-12-5,5 × L	galvanized carbon steel with ceramic coating	6, 7, 8, 9
8	A2-WSW-12-5,5 × L	stainless steel (bi-metal)	14, 15, 16, 17
9	WB6P-6,3 × L	galvanized carbon steel with ≥ 12 µm of zinc	18, 19
10	WB6Px-6,3 × L	galvanized carbon steel with ≥ 20 µm of zinc	18, 19
11	WB6P-D-6,3 × L	galvanized carbon steel with ceramic coating	18, 19
12	A2-WB6P-6,3 × L	stainless steel (bi-metal)	20, 21

2. Specification of the intended use in accordance with the applicable European Assessment Document (EAD)

The fastening screws for sandwich panels are intended to be used for fastening sandwich panels to steel or timber substructures. For details see the Annexes 2 to 21. The component to be fastened is component I and the supporting structure is component II. The sandwich panel can either be used as wall or roof cladding or as load bearing wall and roof element.

The intended use comprises fastening screws for sandwich panels and connections for indoor and outdoor applications. Fastening screws which are intended to be used in external environments with ≥ C2 corrosion according to the standard EN ISO 12944-2 are made of stainless steel.

Furthermore the intended use comprises connections with predominantly static loads (e.g. wind loads, dead loads).

Example of execution of a connections are given in Annex 1.

The provisions made in this European Technical Assessment are based on an assumed working life of the fasteners of 25 years. The indications given on the working life cannot be interpreted as a guarantee given by the producer or Technical Assessment Body, but are to be regarded only as a means for choosing the right

products in relation to the expected economically reasonable working life of the works.

3. Performances of the product and references to the methods used for their assessment

3.1. Performance of the product

3.1.1 Mechanical resistance and stability (BWR 1)

The characteristic values of the shear resistance of connections and tension resistance of connections with the fasteners as well as the maximum head displacement are given in Annex 2 to 21. The values were determined by tests according to EAD 330047-01-0602.

The design values shall be determined according to Annex 22 and EAD 330047-01-0602.

For the corrosion protection the rules given in EN 1993-1-3, EN 1993-1-4 and EN 1999-1-4 shall be taken into account. Fastening screw which are made of stainless steel are intended to be used in external environments \geq C2 corrosion according to the standard EN ISO 12944-2.

3.1.2. Safety in case of fire (BWR 2)

The fastening screws are considered to satisfy the requirements of performance class A1 of reaction to fire, in accordance with the provisions of the EC Decision 96/603/EC (as amended) without the need for testing on the basis of its listing in that decision.

3.1.3. Hygiene, health and the environment (BWR 3)

Regarding the dangerous substances clauses contained in this European Technical Assessment, there may be requirements applicable to the products falling within its scope (e.g. transposed European legislation and national laws, regulations and administrative provisions). In order to meet the provisions of the Construction Products Regulation, these requirements need also to be complied with, when and where they apply.

3.2. Methods used for the assessment

The assessment of fitness of the fasteners for the declared intended use has been made in accordance with EAD 330047-01-0602.

4. Assessment and verification of constancy of performance (AVCP) system applied, with reference to its legal base

According to Decision 1998/214/EC, amended by 2001/596/EC, of the European Commission the system 2+ of assessment and verification of constancy of performance applies (see Annex V to Regulation (EU) No 305/2011).

5. Technical details necessary for the implementation of the AVCP system, as provided for in the applicable European Assessment Document (EAD)

Technical details necessary for the implementation of the AVCP system are laid down in the control plan deposited at the Instytut Techniki Budowlanej.

For type testing the results of the tests performed as part of the assessment for the European Technical Assessment shall be used unless there are changes in the production line or plant. In such cases the necessary type testing has to be agreed between Instytut Techniki Budowlanej and the notified body.

Issued in Warsaw on 30/06/2016 by Instytut Techniki Budowlanej

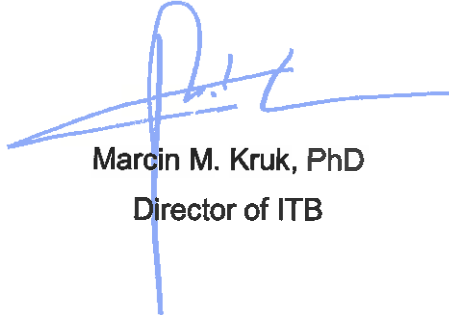

Marcin M. Kruk, PhD
Director of ITB

Examples of execution of a connections

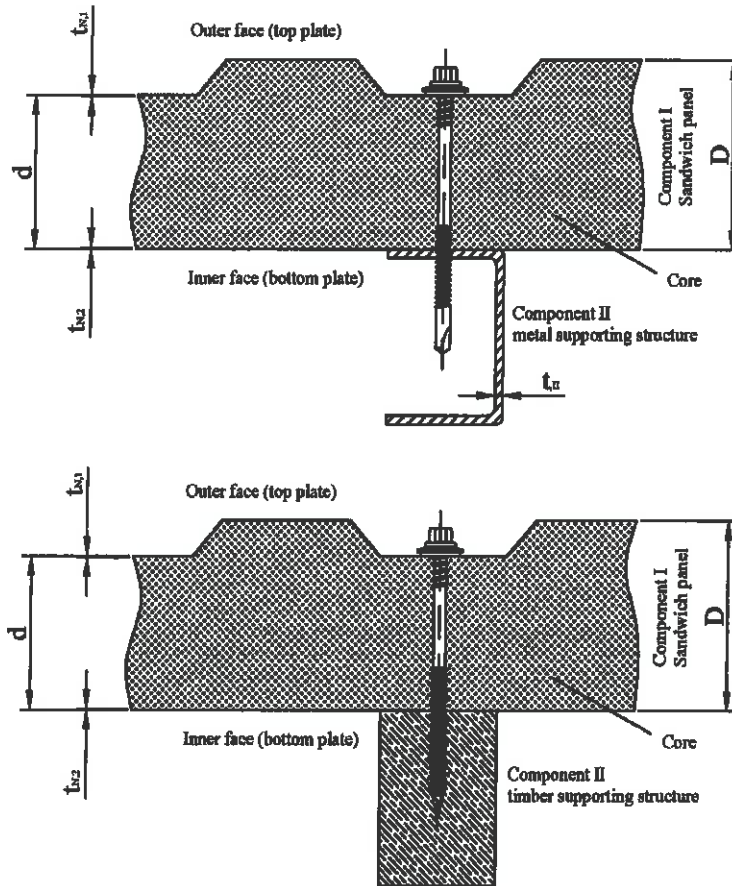

Loading conditions

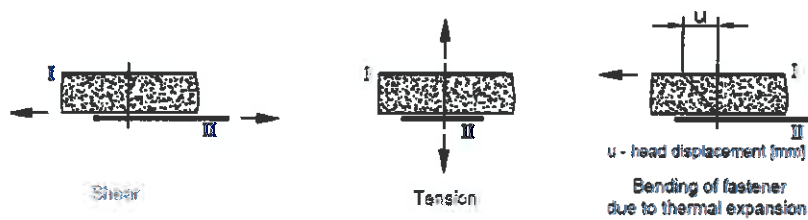

WSW, WSWx, WSWOC, A2-WSW, WB6P, WB6P-D, A2-WB6P
Fastening screws for sandwich panels

Example of execution of a connections. Loading conditions

Annex 1
 of European
 Technical Assessment
 ETA-16/0444

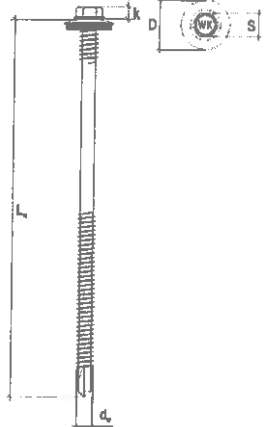
<p>Materials</p> <p>Fastener: carbon steel – SAE1022 quenched, tempered and galvanized or galvanized and additionally protected by ceramic coating</p> <p>Washer: EPDM sealing ring with metal top made of coated carbon steel or stainless steel</p> <p>Component I: S280GD, S320GD or S350GD – EN 10346</p> <p>Component II: $t_{II} < 4$ mm: S235 – EN 10025-1 $t_{II} \geq 4$ mm: S280GD, S320GD or S350GD – EN 10346</p> <p>Drilling capacity: $\Sigma(t_{N2} + t_{II}) \leq 6$ mm</p> <p>Timber substructures no performance assessed</p>	 <p>$L_w = 50-300$ mm $d_w = 5,5$ mm $D = 16$ mm</p>
----------------------------------------------------------------------------------------------------------------------------------------------------------------------------------------------------------------------------------------------------------------------------------------------------------------------------------------------------------------------------------------------------------------------------------------------------------------------------------------------------------------------------------------------------------------------------------------------------------------------------------------------------------	----------------------------------------------------------------------------------------------------------------------------------------------------------------------------------

		Component II: t_{II} [mm]		2,00	2,50	3,00	4,00	5,00
Component I: t_{N1} or t_{N2} [mm]	$V_{R,k}$ [kN]	0,40	0,83	0,83	0,83	0,83	0,83	0,83
		0,50	1,31	1,31	1,31	1,31	1,31	1,31
		0,55	1,31	1,31	1,31	1,31	1,31	1,31
		0,63	1,63	1,63	1,63	1,63	1,63	1,63
		0,75	1,93	1,93	1,93	1,93	1,93	1,93
		0,88	1,93	1,93	1,93	1,93	1,93	1,93
		1,00	1,93	1,93	1,93	1,93	1,93	1,93
	$N_{R,k}$ [kN]	0,40	1,64	1,64	1,64	1,64	1,64	1,64
		0,50	2,37	2,37	2,37	3,02	3,02	3,02
		0,55	2,37	2,37	2,37	3,02	3,02	3,02
		0,63	2,37	2,37	2,37	3,91	3,91	3,91
		0,75	2,37	2,37	2,37	4,17	4,17	4,17
		0,88	2,37	2,37	2,37	4,17	4,17	4,17
		1,00	2,37	2,37	2,37	4,17	4,17	4,17
max. head displacement u depending on the sandwich panel thickness [mm]	30	12	12	12	1,5	1,5	1,5	
	40	12	12	12	1,5	1,5	1,5	
	50	12	12	12	1,5	1,5	1,5	
	60	18	18	18	4	4	4	
	70	18	18	18	4	4	4	
	80	18	18	18	4	4	4	
	90	23	23	23	10	10	10	
	100	23	23	23	10	10	10	
	>140	23	23	23	10	10	10	

WSW, WSWx, WSWOC, A2-WSW, WB6P, WB6P-D, A2-WB6P
Fastening screws for sandwich panels

WSWOC-6-5,5 x L, WSWx-6-5,5 x L and WSW-6-5,5 x L
Self-drilling screws with hexagon head and sealing washer $\geq \text{Ø}16$ mm
with metal top made of coated carbon steel (Z) or stainless steel (S)

Annex 2
of European
Technical Assessment
ETA-16/0444

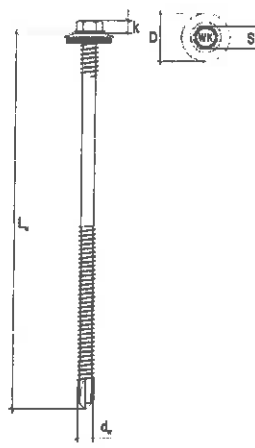
Materials Fastener: carbon steel – SAE1022 quenched, tempered and galvanized or galvanized and additionally protected by ceramic coating Washer: EPDM sealing ring with metal top made of aluminum Component I: S280GD, S320GD or S350GD – EN 10346 Component II: $t_{II} < 4$ mm: S235 – EN 10025-1 $t_{II} \geq 4$ mm: S280GD, S320GD or S350GD – EN 10346		
Drilling capacity: $\Sigma(t_{N2} + t_{II}) \leq 6$ mm		
Timber substructures no performance assessed		$L_w = 50-300$ mm $d_w = 5,5$ mm $D = 16$ mm

		Component II: t_{II} [mm]	2,00	2,50	3,00	4,00	5,00
Component I: t_{N1} or t_{N2} [mm]	$V_{R,k}$ [kN]	0,40	0,83	0,83	0,83	0,83	0,83
		0,50	1,31	1,31	1,31	1,31	1,31
		0,55	1,31	1,31	1,31	1,31	1,31
		0,63	1,63	1,63	1,63	1,63	1,63
		0,75	1,93	1,93	1,93	1,93	1,93
		0,88	1,93	1,93	1,93	1,93	1,93
		1,00	1,93	1,93	1,93	1,93	1,93
	$N_{R,k}$ [kN]	0,40	1,64	1,64	1,64	1,64	1,64
		0,50	2,37	2,37	2,37	2,98	2,98
		0,55	2,37	2,37	2,37	2,98	2,98
		0,63	2,37	2,37	2,37	3,80	3,80
		0,75	2,37	2,37	2,37	3,99	3,99
		0,88	2,37	2,37	2,37	3,99	3,99
		1,00	2,37	2,37	2,37	3,99	3,99
max. head displacement u depending on the sandwich panel thickness [mm]	30	12	12	12	1,5	1,5	
	40	12	12	12	1,5	1,5	
	50	12	12	12	1,5	1,5	
	60	18	18	18	4	4	
	70	18	18	18	4	4	
	80	18	18	18	4	4	
	90	23	23	23	10	10	
	100	23	23	23	10	10	
	120	23	23	23	10	10	
>140	23	23	23	10	10		

WSW, WSWx, WSWOC, A2-WSW, WB6P, WB6P-D, A2-WB6P
Fastening screws for sandwich panels

WSWOC-6-5,5 x L, WSWx-6-5,5 x L and WSW-6-5,5 x L
 Self-drilling screws with hexagon head and sealing washer $\geq \text{Ø}16$ mm
 with metal top made of aluminum (A)

Annex 3
 of European
 Technical Assessment
 ETA-16/0444

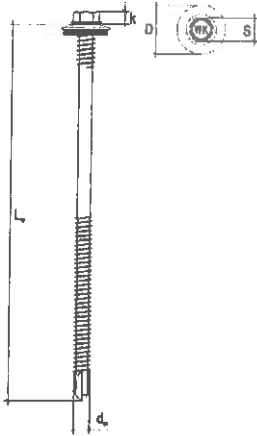
Materials Fastener: carbon steel – SAE1022 quenched, tempered and galvanized or galvanized and additionally protected by ceramic coating Washer: EPDM sealing ring with metal top made of coated carbon steel or stainless steel Component I: S280GD, S320GD or S350GD – EN 10346 Component II: $t_{i1} < 4$ mm: S235 – EN 10025-1 $t_{i1} \geq 4$ mm: S280GD, S320GD or S350GD – EN 10346		
Drilling capacity: $\Sigma(t_{i2} + t_{i1}) \leq 6$ mm		
Timber substructures no performance assessed		$L_w = 50-300$ mm $d_w = 5,5$ mm $D \geq 19$ mm

		Component II: t_i [mm]					
		2,00	2,50	3,00	4,00	5,00	
Component I: t_{i1} or t_{i2} [mm]	$V_{R,k}$ [kN]	0,40	0,83	0,83	0,83	0,83	0,83
		0,50	1,31	1,31	1,31	1,31	1,31
		0,55	1,31	1,31	1,31	1,31	1,31
		0,63	1,63	1,63	1,63	1,63	1,63
		0,75	1,93	1,93	1,93	1,93	1,93
		0,88	1,93	1,93	1,93	1,93	1,93
		1,00	1,93	1,93	1,93	1,93	1,93
	$N_{R,k}$ [kN]	0,40	1,83	1,83	1,83	1,83	1,83
		0,50	2,37	2,37	2,37	3,14	3,14
		0,55	2,37	2,37	2,37	3,14	3,14
		0,63	2,37	2,37	2,37	4,21	4,21
		0,75	2,37	2,37	2,37	4,62	4,62
		0,88	2,37	2,37	2,37	4,62	4,62
		1,00	2,37	2,37	2,37	4,62	4,62
max. head displacement u depending on the sandwich panel thickness [mm]	30	12	12	12	1,5	1,5	
	40	12	12	12	1,5	1,5	
	50	12	12	12	1,5	1,5	
	60	18	18	18	4	4	
	70	18	18	18	4	4	
	80	18	18	18	4	4	
	90	23	23	23	10	10	
	100	23	23	23	10	10	
	120	23	23	23	10	10	
	>140	23	23	23	10	10	

WSW, WSWx, WSWOC, A2-WSW, WB6P, WB6P-D, A2-WB6P
Fastening screws for sandwich panels

WSWOC-6-5,5 x L, WSWx-6-5,5 x L and WSW-6-5,5 x L
 Self-drilling screws with hexagon head and sealing washer $\geq \varnothing 19$ mm
 with metal top made of coated carbon steel (Z) or stainless steel (S)

Annex 4
 of European
 Technical Assessment
 ETA-16/0444

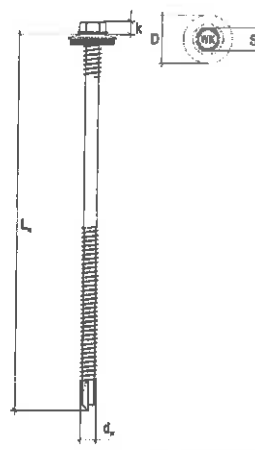
<p>Materials</p> <p>Fastener: carbon steel – SAE 1022 quenched, tempered and galvanized or galvanized and additionally protected by ceramic coating</p> <p>Washer: EPDM sealing ring with metal top made of aluminum</p> <p>Component I: S280GD, S320GD or S350GD – EN 10346</p> <p>Component II: $t_{II} < 4$ mm: S235 – EN 10025-1 $t_{II} \geq 4$ mm: S280GD, S320GD or S350GD – EN 10346</p> <p>Drilling capacity: $\Sigma(t_{IV2} + t_{II}) \leq 6$ mm</p> <p>Timber substructures no performance assessed</p>	 <p>$L_w = 50-300$ mm $d_w = 5,5$ mm $D \geq 19$ mm</p>
------------------------------------------------------------------------------------------------------------------------------------------------------------------------------------------------------------------------------------------------------------------------------------------------------------------------------------------------------------------------------------------------------------------------------------------------------------------------------------------------------------------------------------------------------------------------------------------------------------------------------	-------------------------------------------------------------------------------------------------------------------------------------------------------------------------------------

		Component II: t_{II} [mm]	2,00	2,50	3,00	4,00	5,00
Component I: $t_{IV,1}$ or $t_{IV,2}$ [mm]	V _{R,k} [kN]	0,40	0,83	0,83	0,83	0,83	0,83
		0,50	1,31	1,31	1,31	1,31	1,31
		0,55	1,31	1,31	1,31	1,31	1,31
		0,63	1,63	1,63	1,63	1,63	1,63
		0,75	1,93	1,93	1,93	1,93	1,93
		0,88	1,93	1,93	1,93	1,93	1,93
		1,00	1,93	1,93	1,93	1,93	1,93
	N _{R,k} [kN]	0,40	1,83	1,83	1,83	1,83	1,83
		0,50	2,37	2,37	2,37	3,17	3,17
		0,55	2,37	2,37	2,37	3,17	3,17
		0,63	2,37	2,37	2,37	4,04	4,04
		0,75	2,37	2,37	2,37	4,64	4,64
		0,88	2,37	2,37	2,37	4,64	4,64
		1,00	2,37	2,37	2,37	4,64	4,64
max. head displacement u depending on the sandwich panel thickness [mm]	30	12	12	12	1,5	1,5	
	40	12	12	12	1,5	1,5	
	50	12	12	12	1,5	1,5	
	60	18	18	18	4	4	
	70	18	18	18	4	4	
	80	18	18	18	4	4	
	90	23	23	23	10	10	
	100	23	23	23	10	10	
	>140	23	23	23	10	10	

WSW, WSWx, WSWOC, A2-WSW, WB6P, WB6P-D, A2-WB6P
Fastening screws for sandwich panels

WSWOC-6-5,5 x L, WSWx-6-5,5 x L and WSW-6-5,5 x L
Self-drilling screws with hexagon head and sealing washer $\geq \varnothing 19$ mm
with metal top made of aluminum (A)

Annex 5
of European
Technical Assessment
ETA-16/0444

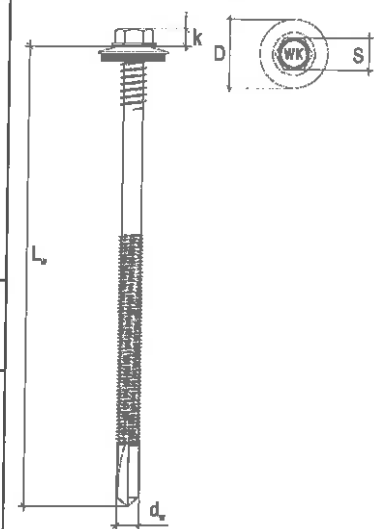
Materials Fastener: carbon steel – SAE1022 quenched, tempered and galvanized or galvanized and additionally protected by ceramic coating Washer: EPDM sealing ring with metal top made of coated carbon steel or stainless steel Component I: S280GD, S320GD or S350GD – EN 10346 Component II: S280GD, S320GD or S350GD – EN 10346		
Drilling capacity: $\Sigma(t_{N2} + t_{ti}) \leq 12 \text{ mm}$		
Timber substructures no performance assessed		L _w = 50-300 mm d _w = 5,5 mm D = 16 mm

Component II: t _{ti} [mm]		4,00	5,00	6,00	8,00	10,00	11,00
Component I: t _{ti1} or t _{ti2} [mm]	V _{R,k} [kN]	0,40	0,83	0,83	0,83	0,83	0,83
		0,50	1,33	1,33	1,33	1,33	1,33
		0,55	1,33	1,33	1,33	1,33	1,33
		0,63	1,62	1,62	1,62	1,62	1,62
		0,75	1,91	1,91	1,91	1,91	1,91
		0,88	1,91	1,91	1,91	1,91	1,91
		1,00	1,91	1,91	1,91	1,91	1,91
	N _{R,k} [kN]	0,40	1,64	1,64	1,64	1,64	1,64
		0,50	3,02	3,02	3,02	3,02	3,02
		0,55	3,02	3,02	3,02	3,02	3,02
		0,63	3,91	3,91	3,91	3,91	3,91
		0,75	4,17	4,17	4,17	4,17	4,17
		0,88	4,17	4,17	4,17	4,17	4,17
		1,00	4,17	4,17	4,17	4,17	4,17
max. head displacement u depending on the sandwich panel thickness [mm]	30	1,5	1,5	1,5	1,5	1,5	
	40	1,5	1,5	1,5	1,5	1,5	
	50	1,5	1,5	1,5	1,5	1,5	
	60	4	4	4	4	4	
	70	4	4	4	4	4	
	80	4	4	4	4	4	
	90	6	6	6	6	6	
	100	6	6	6	6	6	
	>140	6	6	6	6	6	

WSW, WSWx, WSWOC, A2-WSW, WB6P, WB6P-D, A2-WB6P
Fastening screws for sandwich panels

WSWOC-12-5,5 x L, WSWx-12-5,5 x L and WSW-12-5,5 x L
 Self-drilling screws with hexagon head and sealing washer $\geq \text{Ø}16 \text{ mm}$
 with metal top made of coated carbon steel (Z) or stainless steel (S)

Annex 6
 of European
 Technical Assessment
 ETA-16/0444

Materials Fastener: carbon steel – SAE1022 quenched, tempered and galvanized or galvanized and additionally protected by ceramic coating Washer: EPDM sealing ring with metal top made of aluminum Component I: S280GD, S320GD or S350GD – EN 10346 Component II: S280GD, S320GD or S350GD – EN 10346		
Drilling capacity: $\Sigma(t_{N2} + t_{I1}) \leq 12 \text{ mm}$		
Timber substructures no performance assessed		

$L_w = 50-300 \text{ mm}$
 $d_w = 5,5 \text{ mm}$
 $D = 16 \text{ mm}$

Component II: t_{II} [mm]		4,00	5,00	6,00	8,00	10,00	11,00
Component I: t_{N1} or t_{N2} [mm]	$V_{R,k}$ [kN]	0,40	0,83	0,83	0,83	0,83	0,83
		0,50	1,33	1,33	1,33	1,33	1,33
		0,55	1,33	1,33	1,33	1,33	1,33
		0,63	1,62	1,62	1,62	1,62	1,62
		0,75	1,91	1,91	1,91	1,91	1,91
		0,88	1,91	1,91	1,91	1,91	1,91
		1,00	1,91	1,91	1,91	1,91	1,91
	$N_{R,k}$ [kN]	0,40	1,64	1,64	1,64	1,64	1,64
		0,50	2,98	2,98	2,98	2,98	2,98
		0,55	2,98	2,98	2,98	2,98	2,98
		0,63	3,80	3,80	3,80	3,80	3,80
		0,75	3,99	3,99	3,99	3,99	3,99
		0,88	3,99	3,99	3,99	3,99	3,99
		1,00	3,99	3,99	3,99	3,99	3,99
max. head displacement u depending on the sandwich panel thickness [mm]	30	1,5	1,5	1,5	1,5	1,5	
	40	1,5	1,5	1,5	1,5	1,5	
	50	1,5	1,5	1,5	1,5	1,5	
	60	4	4	4	4	4	
	70	4	4	4	4	4	
	80	4	4	4	4	4	
	90	6	6	6	6	6	
	100	6	6	6	6	6	
	120	6	6	6	6	6	
	>140	6	6	6	6	6	

WSW, WSWx, WSWOC, A2-WSW, WB6P, WB6P-D, A2-WB6P
Fastening screws for sandwich panels

WSWOC-12-5,5 x L, WSWx-12-5,5 x L and WSW-12-5,5 x L
 Self-drilling screws with hexagon head and sealing washer $\geq \text{Ø}16 \text{ mm}$
 with metal top made of aluminum (A)

Annex 7
 of European
 Technical Assessment
 ETA-16/0444

<p>Materials Fastener: carbon steel – SAE1022 quenched, tempered and galvanized or galvanized and additionally protected by ceramic coating</p> <p>Washer: EPDM sealing ring with metal top made of coated carbon steel or stainless steel</p> <p>Component I: S280GD, S320GD or S350GD – EN 10346</p> <p>Component II: S280GD, S320GD or S350GD – EN 10346</p>	
<p>Drilling capacity: $\Sigma(t_{n2} + t_{t1}) \leq 12 \text{ mm}$</p>	
<p>Timber substructures no performance assessed</p>	

L_w = 50-300 mm
d_w = 5,5 mm
D ≥ 19 mm

		Component II: t _{ti} [mm]	4,00	5,00	6,00	8,00	10,00	11,00
Component I: t _{n1} , or t _{n2} [mm]	V _{R,k} [kN]	0,40	0,83	0,83	0,83	0,83	0,83	0,83
		0,50	1,33	1,33	1,33	1,33	1,33	1,33
		0,55	1,33	1,33	1,33	1,33	1,33	1,33
		0,63	1,62	1,62	1,62	1,62	1,62	1,62
		0,75	1,91	1,91	1,91	1,91	1,91	1,91
		0,88	1,91	1,91	1,91	1,91	1,91	1,91
		1,00	1,91	1,91	1,91	1,91	1,91	1,91
	N _{R,k} [kN]	0,40	1,83	1,83	1,83	1,83	1,83	1,83
		0,50	3,14	3,14	3,14	3,14	3,14	3,14
		0,55	3,14	3,14	3,14	3,14	3,14	3,14
		0,63	4,21	4,21	4,21	4,21	4,21	4,21
		0,75	4,62	4,62	4,62	4,62	4,62	4,62
		0,88	4,62	4,62	4,62	4,62	4,62	4,62
		1,00	4,62	4,62	4,62	4,62	4,62	4,62
max. head displacement u depending on the sandwich panel thickness [mm]	30	1,5	1,5	1,5	1,5	1,5	1,5	
	40	1,5	1,5	1,5	1,5	1,5	1,5	
	50	1,5	1,5	1,5	1,5	1,5	1,5	
	60	4	4	4	4	4	4	
	70	4	4	4	4	4	4	
	80	4	4	4	4	4	4	
	90	6	6	6	6	6	6	
	100	6	6	6	6	6	6	
	120	6	6	6	6	6	6	
>140	6	6	6	6	6	6		

WSW, WSWx, WSWOC, A2-WSW, WB6P, WB6P-D, A2-WB6P
Fastening screws for sandwich panels

WSWOC-12-5,5 x L, WSWx-12-5,5 x L and WSW-12-5,5 x L
Self-drilling screws with hexagon head and sealing washer ≥ Ø19 mm
with metal top made of coated carbon steel (Z) or stainless steel (S)

Annex 8
of European
Technical Assessment
ETA-16/0444

<p>Materials</p> <p>Fastener: carbon steel – SAE1022 quenched, tempered and galvanized or galvanized and additionally protected by ceramic coating</p> <p>Washer: EPDM sealing ring with metal top made of aluminum</p> <p>Component I: S280GD, S320GD or S350GD – EN 10346</p> <p>Component II: S280GD, S320GD or S350GD – EN 10346</p>	
<p>Drilling capacity: $\Sigma(t_{N2} + t_{II}) \leq 12$ mm</p>	
<p>Timber substructures no performance assessed</p>	

$L_w = 50-300$ mm
 $d_w = 5,5$ mm
 $D \geq 19$ mm

		Component II: t_{II} [mm]					
		4,00	5,00	6,00	8,00	10,00	11,00
Component I: $t_{N,1}$ or $t_{N,2}$ [mm]	V _{R,k} [kN]	0,40	0,83	0,83	0,83	0,83	0,83
		0,50	1,33	1,33	1,33	1,33	1,33
		0,55	1,33	1,33	1,33	1,33	1,33
		0,63	1,62	1,62	1,62	1,62	1,62
		0,75	1,91	1,91	1,91	1,91	1,91
		0,88	1,91	1,91	1,91	1,91	1,91
		1,00	1,91	1,91	1,91	1,91	1,91
	N _{R,k} [kN]	0,40	1,83	1,83	1,83	1,83	1,83
		0,50	3,17	3,17	3,17	3,17	3,17
		0,55	3,17	3,17	3,17	3,17	3,17
		0,63	4,04	4,04	4,04	4,04	4,04
		0,75	4,64	4,64	4,64	4,64	4,64
		0,88	4,64	4,64	4,64	4,64	4,64
		1,00	4,64	4,64	4,64	4,64	4,64
max. head displacement u depending on the sandwich panel thickness [mm]	30	1,5	1,5	1,5	1,5	1,5	
	40	1,5	1,5	1,5	1,5	1,5	
	50	1,5	1,5	1,5	1,5	1,5	
	60	4	4	4	4	4	
	70	4	4	4	4	4	
	80	4	4	4	4	4	
	90	6	6	6	6	6	
	100	6	6	6	6	6	
	120	6	6	6	6	6	
	>140	6	6	6	6	6	

WSW, WSWx, WSWOC, A2-WSW, WB6P, WB6P-D, A2-WB6P
Fastening screws for sandwich panels

WSWOC-12-5,5 x L, WSWx-12-5,5 x L and WSW-12-5,5 x L
Self-drilling screws with hexagon head and sealing washer $\geq \varnothing 19$ mm
with metal top made of aluminum (A)

Annex 9
of European
Technical Assessment
ETA-16/0444

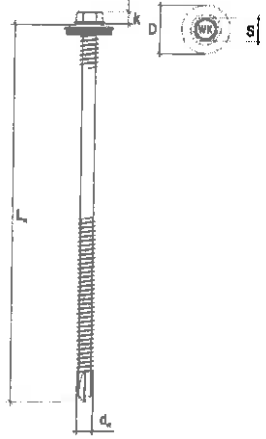
<p>Materials</p> <p>Fastener: stainless steel – SAE304, bi-metal</p> <p>Washer: EPDM sealing ring with metal top made of stainless steel</p> <p>Component I: S280GD, S320GD or S350GD – EN 10346</p> <p>Component II: $t_{f1} < 4$ mm: S235 – EN 10025-1 $t_{f1} \geq 4$ mm: S280GD, S320GD or S350GD – EN 10346</p>	
<p>Drilling capacity: $\Sigma(t_{N2} + t_{f1}) \leq 6$ mm</p>	
<p>Timber substructures</p> <p>no performance assessed</p>	<p>$L = 50-300$ mm $d_w = 5,5$ mm $D = 16$ mm</p>

		Component II: t_{f1} [mm]	2,00	2,50	3,00	4,00	5,00
Component I: $t_{w,1}$ or $t_{w,2}$ [mm]	V _{R,k} [kN]	0,40	0,83	0,83	0,83	0,83	0,83
		0,50	1,31	1,31	1,31	1,31	1,31
		0,55	1,31	1,31	1,31	1,31	1,31
		0,63	1,63	1,63	1,63	1,63	1,63
		0,75	1,93	1,93	1,93	1,93	1,93
		0,88	1,93	1,93	1,93	1,93	1,93
		1,00	1,93	1,93	1,93	1,93	1,93
	N _{R,k} [kN]	0,40	1,64	1,64	1,64	1,64	1,64
		0,50	2,36	2,36	2,36	3,02	3,02
		0,55	2,36	2,36	2,36	3,02	3,02
		0,63	2,36	2,36	2,36	3,91	3,91
		0,75	2,36	2,36	2,36	4,17	4,17
		0,88	2,36	2,36	2,36	4,17	4,17
		1,00	2,36	2,36	2,36	4,17	4,17
max. head displacement u depending on the sandwich panel thickness [mm]	30	12	12	12	1,5	1,5	
	40	12	12	12	1,5	1,5	
	50	12	12	12	1,5	1,5	
	60	18	18	18	4	4	
	70	18	18	18	4	4	
	80	18	18	18	4	4	
	90	23	23	23	10	10	
	100	23	23	23	10	10	
	>140	23	23	23	10	10	

WSW, WSWx, WSWOC, A2-WSW, WB6P, WB6P-D, A2-WB6P
Fastening screws for sandwich panels

A2-WSW-6-5,5 x L
 Self-drilling screws with hexagon head and sealing washer $\geq \varnothing 16$ mm
 with metal top made of stainless steel (S)

Annex 10
 of European
 Technical Assessment
 ETA-16/0444

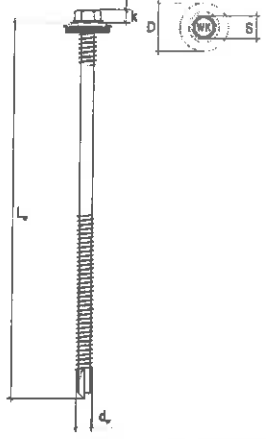
<p>Materials</p> <p>Fastener: stainless steel – SAE304, bi-metal</p> <p>Washer: EPDM sealing ring with metal top made of aluminum</p> <p>Component I: S280GD, S320GD or S350GD – EN 10346</p> <p>Component II: $t_{II} < 4$ mm: S235 – EN 10025-1 $t_{II} \geq 4$ mm: S280GD, S320GD or S350GD – EN 10346</p>		 <p>$L_w = 50-300$ mm $d_w = 5,5$ mm $D = 16$ mm</p>
<p>Drilling capacity: $\Sigma(t_{N2} + t_{II}) \leq 6$ mm</p>		
<p>Timber substructures no performance assessed</p>		

Component II: t_{II} [mm]		2,00	2,50	3,00	4,00	5,00
Component I: $t_{W,1}$ or $t_{W,2}$ [mm]	$V_{R,k}$ [kN]	0,40	0,83	0,83	0,83	0,83
		0,50	1,31	1,31	1,31	1,31
		0,55	1,31	1,31	1,31	1,31
		0,63	1,63	1,63	1,63	1,63
		0,75	1,93	1,93	1,93	1,93
		0,88	1,93	1,93	1,93	1,93
		1,00	1,93	1,93	1,93	1,93
	$N_{R,k}$ [kN]	0,40	1,64	1,64	1,64	1,64
		0,50	2,36	2,36	2,36	2,98
		0,55	2,36	2,36	2,36	2,98
		0,63	2,36	2,36	2,36	3,80
		0,75	2,36	2,36	2,36	3,99
		0,88	2,36	2,36	2,36	3,99
		1,00	2,36	2,36	2,36	3,99
max. head displacement u depending on the sandwich panel thickness [mm]	30	12	12	12	1,5	
	40	12	12	12	1,5	
	50	12	12	12	1,5	
	60	18	18	18	4	
	70	18	18	18	4	
	80	18	18	18	4	
	90	23	23	23	10	
	100	23	23	23	10	
	120	23	23	23	10	
>140	23	23	23	10		

WSW, WSWx, WSWOC, A2-WSW, WB6P, WB6P-D, A2-WB6P
Fastening screws for sandwich panels

A2-WSW-6-5,5 x L
Self-drilling screws with hexagon head and sealing washer $\geq \varnothing 16$ mm with metal top made of aluminum (A)

Annex 11
of European
Technical Assessment
ETA-16/0444

Materials
Fastener: stainless steel – SAE304, bi-metal
Washer: EPDM sealing ring with metal top made of stainless steel
Component I: S280GD, S320GD or S350GD – EN 10346
Component II: $t_{ij} < 4$ mm: S235 – EN 10025-1
 $t_{ij} \geq 4$ mm: S280GD, S320GD or S350GD – EN 10346

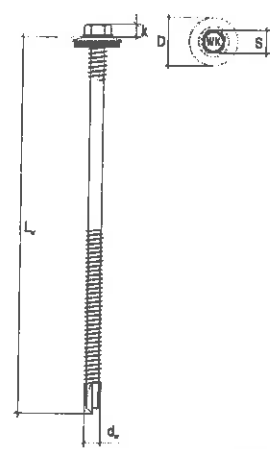

$L_w = 50-300$ mm
 $d_w = 5,5$ mm
 $D \geq 19$ mm

Drilling capacity: $\Sigma(t_{N2} + t_{ij}) \leq 6$ mm

Timber substructures
 no performance assessed

		Component II: t_{ij} [mm]	2,00	2,50	3,00	4,00	5,00
Component I: t_{N1} or t_{N2} [mm]	$V_{R,k}$ [kN]	0,40	0,83	0,83	0,83	0,83	0,83
		0,50	1,31	1,31	1,31	1,31	1,31
		0,55	1,31	1,31	1,31	1,31	1,31
		0,63	1,63	1,63	1,63	1,63	1,63
		0,75	1,93	1,93	1,93	1,93	1,93
		0,88	1,93	1,93	1,93	1,93	1,93
		1,00	1,93	1,93	1,93	1,93	1,93
	$N_{R,k}$ [kN]	0,40	1,83	1,83	1,83	1,83	1,83
		0,50	2,36	2,36	2,36	3,14	3,14
		0,55	2,36	2,36	2,36	3,14	3,14
		0,63	2,36	2,36	2,36	4,21	4,21
		0,75	2,36	2,36	2,36	4,62	4,62
		0,88	2,36	2,36	2,36	4,62	4,62
		1,00	2,36	2,36	2,36	4,62	4,62
max. head displacement u depending on the sandwich panel thickness [mm]	30	12	12	12	1,5	1,5	
	40	12	12	12	1,5	1,5	
	50	12	12	12	1,5	1,5	
	60	18	18	18	4	4	
	70	18	18	18	4	4	
	80	18	18	18	4	4	
	90	23	23	23	10	10	
	100	23	23	23	10	10	
	120	23	23	23	10	10	
	>140	23	23	23	10	10	

WSW, WSWx, WSWOC, A2-WSW, WB6P, WB6P-D, A2-WB6P
Fastening screws for sandwich panels

A2-WSW-6-5,5 x L
 Self-drilling screws with hexagon head and sealing washer $\geq \varnothing 19$ mm with metal top made of stainless steel (S)

Annex 12
 of European
 Technical Assessment
 ETA-16/0444

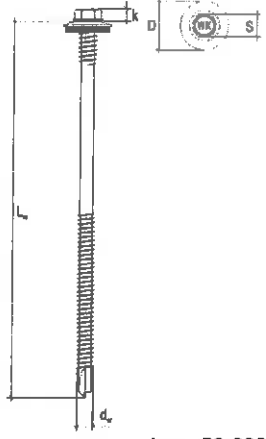
Materials Fastener: stainless steel – SAE304, bi-metal Washer: EPDM sealing ring with metal top made of aluminum Component I: S280GD, S320GD or S350GD – EN 10346 Component II: $t_{II} < 4$ mm: S235 – EN 10025-1 $t_{II} \geq 4$ mm: S280GD, S320GD or S350GD – EN 10346		 <p> $L_w = 50-300$ mm $d_w = 5,5$ mm $D \geq 19$ mm </p>
Drilling capacity: $\Sigma(t_{II} + t_{II}) \leq 6$ mm		
Timber substructures no performance assessed		

		Component II: t_{II} [mm]	2,00	2,50	3,00	4,00	5,00
Component I: $t_{II,1}$ or $t_{II,2}$ [mm]	$V_{R,k}$ [kN]	0,40	0,83	0,83	0,83	0,83	0,83
		0,50	1,31	1,31	1,31	1,31	1,31
		0,55	1,31	1,31	1,31	1,31	1,31
		0,63	1,63	1,63	1,63	1,63	1,63
		0,75	1,93	1,93	1,93	1,93	1,93
		0,88	1,93	1,93	1,93	1,93	1,93
		1,00	1,93	1,93	1,93	1,93	1,93
	$N_{R,k}$ [kN]	0,40	1,83	1,83	1,83	1,83	1,83
		0,50	2,36	2,36	2,36	3,17	3,17
		0,55	2,36	2,36	2,36	3,17	3,17
		0,63	2,36	2,36	2,36	4,04	4,04
		0,75	2,36	2,36	2,36	4,64	4,64
		0,88	2,36	2,36	2,36	4,64	4,64
		1,00	2,36	2,36	2,36	4,64	4,64
max. head displacement u depending on the sandwich panel thickness [mm]	30	12	12	12	1,5	1,5	
	40	12	12	12	1,5	1,5	
	50	12	12	12	1,5	1,5	
	60	18	18	18	4	4	
	70	18	18	18	4	4	
	80	18	18	18	4	4	
	90	23	23	23	10	10	
	100	23	23	23	10	10	
	120	23	23	23	10	10	
>140	23	23	23	10	10		

WSW, WSWx, WSWOC, A2-WSW, WB6P, WB6P-D, A2-WB6P Fastening screws for sandwich panels	Annex 13 of European Technical Assessment ETA-16/0444
A2-WSW-6-5,5 x L Self-drilling screws with hexagon head and sealing washer $\geq \varnothing 19$ mm with metal top made of aluminum (A)	

Materials
Fastener: stainless steel – SAE304, bi-metal
Washer: EPDM sealing ring with metal top made of stainless steel
Component I: S280GD, S320GD or S350GD – EN 10346
Component II: S280GD, S320GD or S350GD – EN 10346

Drilling capacity: $\Sigma(t_{N2} + t_{I1}) \leq 12$ mm

Timber substructures
 no performance assessed

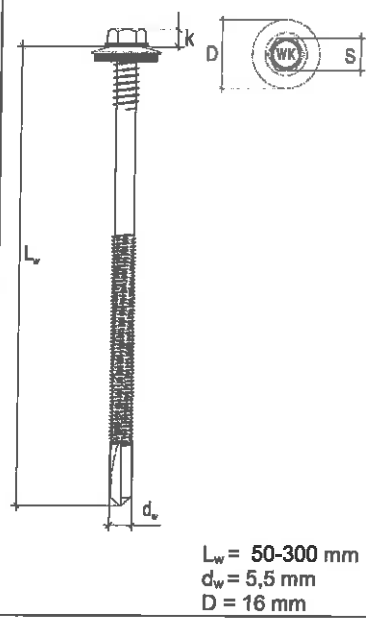

		Component II: t_{II} [mm]	4,00	5,00	6,00	8,00	10,00	11,00
Component I: t_{I1} or t_{I2} [mm]	V _{R,k} [kN]	0,40	0,83	0,83	0,83	0,83	0,83	0,83
		0,50	1,33	1,33	1,33	1,33	1,33	1,33
		0,55	1,33	1,33	1,33	1,33	1,33	1,33
		0,63	1,62	1,62	1,62	1,62	1,62	1,62
		0,75	1,91	1,91	1,91	1,91	1,91	1,91
		0,88	1,91	1,91	1,91	1,91	1,91	1,91
		1,00	1,91	1,91	1,91	1,91	1,91	1,91
	N _{R,k} [kN]	0,40	1,64	1,64	1,64	1,64	1,64	1,64
		0,50	3,02	3,02	3,02	3,02	3,02	3,02
		0,55	3,02	3,02	3,02	3,02	3,02	3,02
		0,63	3,91	3,91	3,91	3,91	3,91	3,91
		0,75	4,17	4,17	4,17	4,17	4,17	4,17
		0,88	4,17	4,17	4,17	4,17	4,17	4,17
		1,00	4,17	4,17	4,17	4,17	4,17	4,17
max. head displacement u depending on the sandwich panel thickness [mm]	30	1,5	1,5	1,5	1,5	1,5	1,5	
	40	1,5	1,5	1,5	1,5	1,5	1,5	
	50	1,5	1,5	1,5	1,5	1,5	1,5	
	60	4	4	4	4	4	4	
	70	4	4	4	4	4	4	
	80	4	4	4	4	4	4	
	90	6	6	6	6	6	6	
	100	6	6	6	6	6	6	
	120	6	6	6	6	6	6	
	>140	6	6	6	6	6	6	

WSW, WSWx, WSWOC, A2-WSW, WB6P, WB6P-D, A2-WB6P
 Fastening screws for sandwich panels

A2-WSW-12-5,5 x L
 Self-drilling screws with hexagon head and sealing washer $\geq \varnothing 16$ mm with metal top made of stainless steel (S)

Annex 14
 of European
 Technical Assessment
 ETA-16/0444

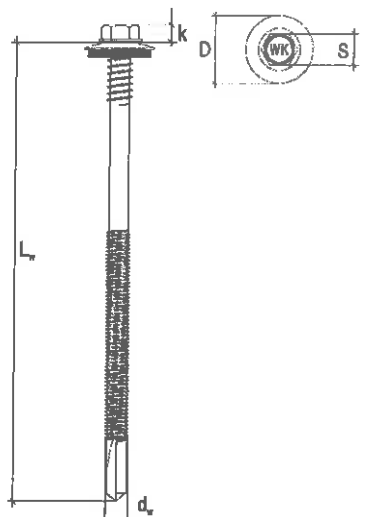
<p>Materials Fastener: stainless steel – SAE304, bi-metal Washer: EPDM sealing ring with metal top made of aluminum Component I: S280GD, S320GD or S350GD – EN 10346 Component II: S280GD, S320GD or S350GD – EN 10346</p>	
<p>Drilling capacity: $\Sigma(t_{N2} + t_{fl}) \leq 12 \text{ mm}$</p>	
<p><u>Timber substructures</u> no performance assessed</p>	

L_w = 50-300 mm
 d_w = 5,5 mm
 D = 16 mm

		Component II: t _{fl} [mm]	4,00	5,00	6,00	8,00	10,00	11,00
Component I: t _{N,1} or t _{N,2} [mm]	V _{R,k} [kN]	0,40	0,83	0,83	0,83	0,83	0,83	0,83
		0,50	1,33	1,33	1,33	1,33	1,33	1,33
		0,55	1,33	1,33	1,33	1,33	1,33	1,33
		0,63	1,62	1,62	1,62	1,62	1,62	1,62
		0,75	1,91	1,91	1,91	1,91	1,91	1,91
		0,88	1,91	1,91	1,91	1,91	1,91	1,91
		1,00	1,91	1,91	1,91	1,91	1,91	1,91
	N _{R,k} [kN]	0,40	1,64	1,64	1,64	1,64	1,64	1,64
		0,50	2,98	2,98	2,98	2,98	2,98	2,98
		0,55	2,98	2,98	2,98	2,98	2,98	2,98
		0,63	3,80	3,80	3,80	3,80	3,80	3,80
		0,75	3,99	3,99	3,99	3,99	3,99	3,99
		0,88	3,99	3,99	3,99	3,99	3,99	3,99
		1,00	3,99	3,99	3,99	3,99	3,99	3,99
max. head displacement u depending on the sandwich panel thickness [mm]	30	1,5	1,5	1,5	1,5	1,5	1,5	
	40	1,5	1,5	1,5	1,5	1,5	1,5	
	50	1,5	1,5	1,5	1,5	1,5	1,5	
	60	4	4	4	4	4	4	
	70	4	4	4	4	4	4	
	80	4	4	4	4	4	4	
	90	6	6	6	6	6	6	
	100	6	6	6	6	6	6	
	120	6	6	6	6	6	6	
>140	6	6	6	6	6	6		

<p>WSW, WSWx, WSWOC, A2-WSW, WB6P, WB6P-D, A2-WB6P Fastening screws for sandwich panels</p>	<p>Annex 15 of European Technical Assessment ETA-16/0444</p>
<p>A2-WSW-12-5,5 x L Self-drilling screws with hexagon head and sealing washer ≥ Ø16 mm with metal top made of aluminum (A)</p>	

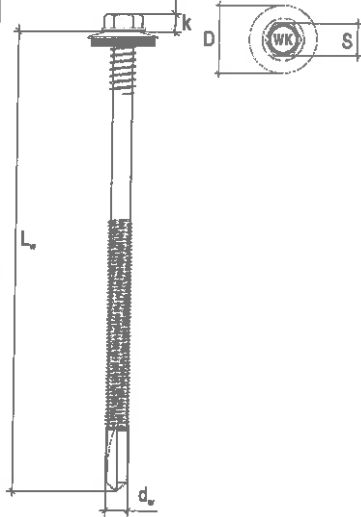
Materials Fastener: stainless steel – SAE304, bi-metal Washer: EPDM sealing ring with metal top made of stainless steel Component I: S280GD, S320GD or S350GD – EN 10346 Component II: S280GD, S320GD or S350GD – EN 10346		 <p style="text-align: right;"> L_w = 50-300 mm d_w = 5,5 mm D ≥ 19 mm </p>
Drilling capacity: $\Sigma(t_{N2} + t_I) \leq 12$ mm		
Timber substructures no performance assessed		

		Component II: t _{II} [mm]	4,00	5,00	6,00	8,00	10,00	11,00
Component I: t _{N,1} or t _{N,2} [mm]	V _{R,k} [kN]	0,40	0,83	0,83	0,83	0,83	0,83	0,83
		0,50	1,33	1,33	1,33	1,33	1,33	1,33
		0,55	1,33	1,33	1,33	1,33	1,33	1,33
		0,63	1,62	1,62	1,62	1,62	1,62	1,62
		0,75	1,91	1,91	1,91	1,91	1,91	1,91
		0,88	1,91	1,91	1,91	1,91	1,91	1,91
		1,00	1,91	1,91	1,91	1,91	1,91	1,91
	N _{R,k} [kN]	0,40	1,83	1,83	1,83	1,83	1,83	1,83
		0,50	3,14	3,14	3,14	3,14	3,14	3,14
		0,55	3,14	3,14	3,14	3,14	3,14	3,14
		0,63	4,21	4,21	4,21	4,21	4,21	4,21
		0,75	4,62	4,62	4,62	4,62	4,62	4,62
		0,88	4,62	4,62	4,62	4,62	4,62	4,62
		1,00	4,62	4,62	4,62	4,62	4,62	4,62
max. head displacement u depending on the sandwich panel thickness [mm]	30	1,5	1,5	1,5	1,5	1,5	1,5	
	40	1,5	1,5	1,5	1,5	1,5	1,5	
	50	1,5	1,5	1,5	1,5	1,5	1,5	
	60	4	4	4	4	4	4	
	70	4	4	4	4	4	4	
	80	4	4	4	4	4	4	
	90	6	6	6	6	6	6	
	100	6	6	6	6	6	6	
	120	6	6	6	6	6	6	
	>140	6	6	6	6	6	6	

WSW, WSWx, WSWOC, A2-WSW, WB6P, WB6P-D, A2-WB6P
 Fastening screws for sandwich panels

A2-WSW-12-5,5 x L
 Self-drilling screws with hexagon head and sealing washer ≥ Ø19 mm
 with metal top made of stainless steel (S)

Annex 16
 of European
 Technical Assessment
 ETA-16/0444

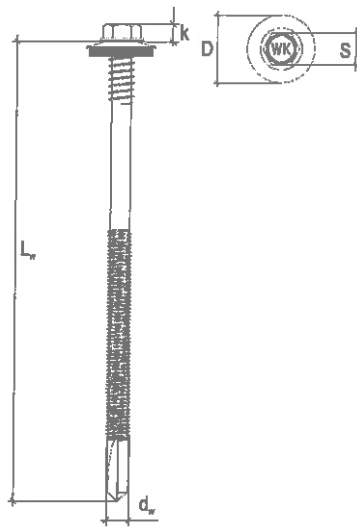
Materials Fastener: stainless steel – SAE304, bi-metal Washer: EPDM sealing ring with metal top made of aluminum Component I: S280GD, S320GD or S350GD – EN 10346 Component II: S280GD, S320GD or S350GD – EN 10346		
Drilling capacity: $\Sigma(t_{N2} + t_{II}) \leq 12 \text{ mm}$		
Timber substructures no performance assessed		

$L_w = 50-300 \text{ mm}$
 $d_w = 5,5 \text{ mm}$
 $D \geq 19 \text{ mm}$

		Component II: t_{II} [mm]	4,00	5,00	6,00	8,00	10,00	11,00
Component I: $t_{N,1}$ or $t_{N,2}$ [mm]	$V_{R,k}$ [kN]	0,40	0,83	0,83	0,83	0,83	0,83	0,83
		0,50	1,33	1,33	1,33	1,33	1,33	1,33
		0,55	1,33	1,33	1,33	1,33	1,33	1,33
		0,63	1,62	1,62	1,62	1,62	1,62	1,62
		0,75	1,91	1,91	1,91	1,91	1,91	1,91
		0,88	1,91	1,91	1,91	1,91	1,91	1,91
		1,00	1,91	1,91	1,91	1,91	1,91	1,91
	$N_{R,k}$ [kN]	0,40	1,83	1,83	1,83	1,83	1,83	1,83
		0,50	3,17	3,17	3,17	3,17	3,17	3,17
		0,55	3,17	3,17	3,17	3,17	3,17	3,17
		0,63	4,04	4,04	4,04	4,04	4,04	4,04
		0,75	4,64	4,64	4,64	4,64	4,64	4,64
		0,88	4,64	4,64	4,64	4,64	4,64	4,64
		1,00	4,64	4,64	4,64	4,64	4,64	4,64
max. head displacement u depending on the sandwich panel thickness in [mm]	30	1,5	1,5	1,5	1,5	1,5	1,5	
	40	1,5	1,5	1,5	1,5	1,5	1,5	
	50	1,5	1,5	1,5	1,5	1,5	1,5	
	60	4	4	4	4	4	4	
	70	4	4	4	4	4	4	
	80	4	4	4	4	4	4	
	90	6	6	6	6	6	6	
	100	6	6	6	6	6	6	
	120	6	6	6	6	6	6	
	>140	6	6	6	6	6	6	

WSW, WSWx, WSWOC, A2-WSW, WB6P, WB6P-D, A2-WB6P Fastening screws for sandwich panels	Annex 17 of European Technical Assessment ETA-16/0444
A2-WSW-12-5,5 x L Self-drilling screws with hexagon head and sealing washer $\geq \text{Ø}19 \text{ mm}$ with metal top made of aluminum (A)	

<p>Materials</p> <p>Fastener: carbon steel – SAE1022 quenched, tempered and galvanized ($\geq 12 \mu\text{m}$)</p> <p>Washer: EPDM sealing ring with metal top made of coated carbon steel or stainless steel</p> <p>Component I: S280GD, S320GD or S350GD – EN 10346</p> <p>Component II: structural timber – EN 14081</p>	
<p>Drilling capacity: —</p>	
<p>Timber substructures</p> <p>For timber substructures performance assessed with</p> <p>$M_{y,Rk} = 8,910 \text{ Nm}$</p> <p>$f_{ax,k} = 16,586 \text{ N/mm}^2$ for $l_{ef} \geq 30 \text{ mm}$</p>	<p>$L_w = 30\text{-}300 \text{ mm}$ $d_w = 6,3 \text{ mm}$ $D \geq 19 \text{ mm}$</p>

Component II: wood class $\geq \text{C24}$			Effective length l_{ef} [mm]								
			$\geq 30,00$	-	-	-	-	-	-		
Component I: $t_{w,1}$ lub $t_{w,2}$ [mm]	V _{R,k} [kN]	0,40	0,87	-	-	-	-	-	-	-	-
		0,50	1,35	-	-	-	-	-	-	-	-
		0,55	1,35	-	-	-	-	-	-	-	-
		0,63	1,70	-	-	-	-	-	-	-	-
		0,75	2,10	-	-	-	-	-	-	-	-
		0,88	2,10	-	-	-	-	-	-	-	-
		1,00	2,10	-	-	-	-	-	-	-	-
	N _{R,k} [kN]	0,40	1,83	-	-	-	-	-	-	-	-
		0,50	3,13	-	-	-	-	-	-	-	-
		0,55	3,13	-	-	-	-	-	-	-	-
		0,63	3,13	-	-	-	-	-	-	-	-
		0,75	3,13	-	-	-	-	-	-	-	-
		0,88	3,13	-	-	-	-	-	-	-	-
		1,00	3,13	-	-	-	-	-	-	-	-
max. head displacement u depending on the sandwich panel thickness [mm]	30	1	-	-	-	-	-	-	-	-	
	40	1	-	-	-	-	-	-	-	-	
	50	1	-	-	-	-	-	-	-	-	
	60	1,5	-	-	-	-	-	-	-	-	
	70	1,5	-	-	-	-	-	-	-	-	
	80	1,5	-	-	-	-	-	-	-	-	
	90	2	-	-	-	-	-	-	-	-	
	100	2	-	-	-	-	-	-	-	-	
	120	2	-	-	-	-	-	-	-	-	
	≥ 140	2	-	-	-	-	-	-	-	-	

WSW, WSWx, WSWOC, A2-WSW, WB6P, WB6P-D, A2-WB6P
Fastening screws for sandwich panels

WB6P-6,3 x L, WB6Px-6,3 x L, WB6P-D-6,3 x L
 Self-tapping screws with hexagon head and sealing washer $\geq \text{Ø}19 \text{ mm}$
 with metal top made of coated carbon steel (Z) or stainless steel (S)

Annex 18
 of European
 Technical Assessment
 ETA-16/0444

<p>Materials Fastener: carbon steel – SAE1022 quenched, tempered and galvanized ($\geq 12 \mu\text{m}$)</p> <p>Washer: EPDM sealing ring with metal top made of aluminum</p> <p>Component I: S280GD, S320GD or S350GD – EN 10346</p> <p>Component II: structural timber – EN 14081</p>	
Drilling capacity: —	
<p>Timber substructures For timber substructures performance assessed with $M_{y,Rk} = 8,910 \text{ Nm}$ $f_{ex,k} = 16,586 \text{ N/mm}^2$ for $l_{ef} \geq 30 \text{ mm}$</p>	$L_w = 30\text{-}300 \text{ mm}$ $d_w = 6,3 \text{ mm}$ $D \geq 19 \text{ mm}$

Component II: wood class \geq C24			Effective length l_{ef} [mm]							
			$\geq 30,00$	-	-	-	-	-	-	
Component I: $t_{d,1}$ lub $t_{d,2}$ [mm]	V _{R,k} [kN]	0,40	0,87	-	-	-	-	-	-	-
		0,50	1,35	-	-	-	-	-	-	-
		0,55	1,35	-	-	-	-	-	-	-
		0,63	1,70	-	-	-	-	-	-	-
		0,75	2,10	-	-	-	-	-	-	-
		0,88	2,10	-	-	-	-	-	-	-
	N _{R,k} [kN]	0,40	1,83	-	-	-	-	-	-	-
		0,50	3,13	-	-	-	-	-	-	-
		0,55	3,13	-	-	-	-	-	-	-
		0,63	3,13	-	-	-	-	-	-	-
		0,75	3,13	-	-	-	-	-	-	-
		1,00	3,13	-	-	-	-	-	-	-
	max. head displacement u depending on the sandwich panel thickness [mm]	30	1	-	-	-	-	-	-	-
		40	1	-	-	-	-	-	-	-
50		1	-	-	-	-	-	-	-	
60		1,5	-	-	-	-	-	-	-	
70		1,5	-	-	-	-	-	-	-	
80		1,5	-	-	-	-	-	-	-	
90		2	-	-	-	-	-	-	-	
100		2	-	-	-	-	-	-	-	
≥ 140		2	-	-	-	-	-	-	-	

<p>WSW, WSWx, WSWOC, A2-WSW, WB6P, WB6P-D, A2-WB6P Fastening screws for sandwich panels</p>	<p>Annex 19 of European Technical Assessment ETA-16/0444</p>
<p>WB6P-6,3 x L, WB6Px-6,3 x L, WB6P-D-6,3 x L Self-tapping screws with hexagon head and sealing washer $\geq \text{Ø}19 \text{ mm}$ with metal top made of aluminum (A)</p>	

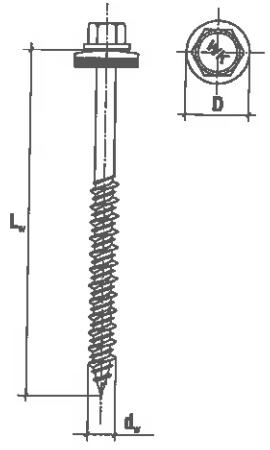
Materials Fastener: stainless steel – SAE304 Washer: EPDM sealing ring with metal top made of stainless steel Component I: S280GD, S320GD or S350GD – EN 10346 Component II: structural timber – EN 14081		
Drilling capacity: —		
Timber substructures For timber substructures performance assessed with $M_{y,Rk} = 6,830 \text{ Nm}$ $f_{ax,k} = 16,586 \text{ N/mm}^2$ for $l_{ef} \geq 30 \text{ mm}$		

$L_w = 30\text{-}300 \text{ mm}$
 $d_w = 6,3 \text{ mm}$
 $D \geq 19 \text{ mm}$

Component II: wood class \geq C24			Effective length l_{ef} (mm)								
			$\geq 30,00$	-	-	-	-	-	-	-	
Component I: $t_{w,1}$ lub $t_{w,2}$ [mm]	$V_{R,k}$ [kN]	0,40	0,87	-	-	-	-	-	-	-	-
		0,50	1,35	-	-	-	-	-	-	-	-
		0,55	1,35	-	-	-	-	-	-	-	-
		0,63	1,70	-	-	-	-	-	-	-	-
		0,75	2,10	-	-	-	-	-	-	-	-
		0,88	2,10	-	-	-	-	-	-	-	-
		1,00	2,10	-	-	-	-	-	-	-	-
	$N_{R,k}$ [kN]	0,40	1,83	-	-	-	-	-	-	-	-
		0,50	3,13	-	-	-	-	-	-	-	-
		0,55	3,13	-	-	-	-	-	-	-	-
		0,63	3,13	-	-	-	-	-	-	-	-
		0,75	3,13	-	-	-	-	-	-	-	-
		0,88	3,13	-	-	-	-	-	-	-	-
		1,00	3,13	-	-	-	-	-	-	-	-
max. head displacement u depending on the sandwich panel thickness [mm]	30	1	-	-	-	-	-	-	-	-	
	40	1	-	-	-	-	-	-	-	-	
	50	1	-	-	-	-	-	-	-	-	
	60	1,5	-	-	-	-	-	-	-	-	
	70	1,5	-	-	-	-	-	-	-	-	
	80	1,5	-	-	-	-	-	-	-	-	
	90	2	-	-	-	-	-	-	-	-	
	100	2	-	-	-	-	-	-	-	-	
	120	2	-	-	-	-	-	-	-	-	
	≥ 140	2	-	-	-	-	-	-	-	-	

WSW, WSWx, WSWOC, A2-WSW, WB6P, WB6P-D, A2-WB6P
Fastening screws for sandwich panels

A2-WB6P-6,3 x L
Self-tapping screws with hexagon head and sealing washer $\geq \varnothing 19 \text{ mm}$
with metal top made of stainless steel (S)

Annex 20
of European
Technical Assessment
ETA-16/0444

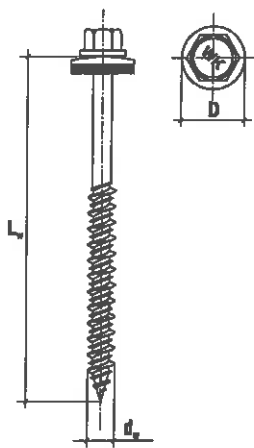
<p>Materials Fastener: stainless steel – SAE304 Washer: EPDM sealing ring with metal top made of aluminum Component I: S280GD, S320GD or S350GD – EN 10346 Component II: structural timber – EN 14081</p>	
Drilling capacity: —	
<p>Timber substructures For timber substructures performance assessed with $M_{y,Rk} = 6,830 \text{ Nm}$ $f_{ax,k} = 16,586 \text{ N/mm}^2$ for $l_{ef} \geq 30 \text{ mm}$</p>	$L_w = 30-300 \text{ mm}$ $d_w = 6,3 \text{ mm}$ $D \geq 19 \text{ mm}$

Component II: wood class \geq C24		Effective length l_{ef} [mm]								
		$\geq 30,00$	-	-	-	-	-	-	-	
Component I: $t_{w,1}$ lub $t_{w,2}$ [mm]	V _{R,k} [kN]	0,40	0,87	-	-	-	-	-	-	-
		0,50	1,35	-	-	-	-	-	-	-
		0,55	1,35	-	-	-	-	-	-	-
		0,63	1,70	-	-	-	-	-	-	-
		0,75	2,10	-	-	-	-	-	-	-
		0,88	2,10	-	-	-	-	-	-	-
		1,00	2,10	-	-	-	-	-	-	-
	N _{R,k} [kN]	0,40	1,83	-	-	-	-	-	-	-
		0,50	3,13	-	-	-	-	-	-	-
		0,55	3,13	-	-	-	-	-	-	-
		0,63	3,13	-	-	-	-	-	-	-
		0,75	3,13	-	-	-	-	-	-	-
		0,88	3,13	-	-	-	-	-	-	-
		1,00	3,13	-	-	-	-	-	-	-
max. head displacement u depending on the sandwich panel thickness [mm]	30	1	-	-	-	-	-	-	-	
	40	1	-	-	-	-	-	-	-	
	50	1	-	-	-	-	-	-	-	
	60	1,5	-	-	-	-	-	-	-	
	70	1,5	-	-	-	-	-	-	-	
	80	1,5	-	-	-	-	-	-	-	
	90	2	-	-	-	-	-	-	-	
	100	2	-	-	-	-	-	-	-	
	120	2	-	-	-	-	-	-	-	
≥ 140	2	-	-	-	-	-	-	-		

<p>WSW, WSWx, WSWOC, A2-WSW, WB6P, WB6P-D, A2-WB6P Fastening screws for sandwich panels</p>	<p>Annex 21 of European Technical Assessment ETA-16/0444</p>
<p>A2-WB6P-6,3 x L Self-tapping screws with hexagon head and sealing washer $\geq \varnothing 19 \text{ mm}$ with metal top made of aluminum (A)</p>	

Determination of Design Values

1. Determination of Design Shear Resistance

The determination of the design values of the shear resistance depends on the type of substructure.

For Metal Supporting Substructures the following applies:

The design values $V_{R,d}$ of the shear resistance are the characteristic values of the shear resistance divided by the recommended partial safety factor $\gamma_M = 1,33$. The recommended partial safety factor γ_M should be used in cases where no value is given in national regulations of the Member State where the fastening screws are used.

For Timber Supporting Substructures the following applies:

The design values $V_{R,d}$ of the shear resistance are the characteristic values of the shear resistance multiplied by k_{mod} according to EN 1995-1-1 Section 8.7 (Screwed connections), Table 3.1, and divided by the recommended partial safety factor $\gamma_M = 1,33$. If failure of the inner face with the thickness t_{N2} and not failure of the timber substructure is the relevant failure mode then $k_{mod} = 1.0$.

The recommended partial safety factor γ_M should be used in cases where no value is given in national regulations of the Member State where the fastening screws are used.

2. Determination of Design Pull-through, Pull-out and Tension Resistance

The design values of the pull-through resistance are the characteristic values of the pull-through resistance divided by the recommended partial safety factor $\gamma_M = 1,33$. The recommended partial safety factor γ_M should be used in cases where no value is given in national regulations of the Member State where the fastening screws are used.

The determination of the design values of the pull-out resistance depends on the type of substructure.

For Metal Supporting Substructures the following applies:

The design values of the pull-out resistance are the characteristic values of the pull-out resistance divided by the recommended partial safety factor $\gamma_M = 1,33$. The recommended partial safety factor γ_M should be used in cases where no value is given in national regulations of the Member State where the fastening screws are used.

For Timber Supporting Substructures the following applies:

The design values of the pull-out resistance are the characteristic values of the pull-out resistance multiplied by k_{mod} according to EN 1995-1-1 Section 8.7 (Screwed connections), Table 3.1, and divided by the recommended partial safety factor $\gamma_M = 1,33$. The recommended partial safety factor γ_M should be used in cases where no value is given in national regulations of the Member State where the fastening screws are used.

The design tension resistance $N_{R,d}$ is the minimum value of the design values of either pull-through resistance or relevant pull-out resistance for the corresponding connection.

3. Design Resistance in case of combined Tension and Shear Forces (interaction)

In case of combined tension and shear forces the linear interaction formula according to EN 1993-1-3, section 8.3 (8) or EN 1999-1-4, section 8.1 (7) should be taken into account.

**WFD, WDD, WSB, WSBP, WS, WF, WSS, WB6
Fastening screws for metal members and sheeting**

Determination of Design Values

Annex 22
of European
Technical Assessment
ETA-16/0444

